



HÖRMANN

KNX-Gateway

Art. no. 4511630

Product documentation

Table of Contents

1	Information on the product	3
1.1	Product catalogue	3
1.2	Function	3
1.3	Device components	3
1.4	Technical data.....	3
2	Safety instructions	5
3	Fitting and electrical connection	6
4	Commissioning	8
5	Application programs	9
6	Scope of functions	10
7	Notes on software	11
8	Name of the drive	12
8.1	Name of the drive parameter	12
9	Drive type	13
9.1	Drive type parameter	13
10	Drive movement	15
10.1	Drive movement parameter	15
10.2	Drive movement object list.....	15
11	Drive lighting	17
11.1	Drive lighting parameter	17
11.2	Drive lighting object list	17
12	Behaviour in case of restart	18
12.1	Behaviour after bus voltage return parameter	18
13	Status displays	20
13.1	Status displays parameter	20
13.2	Status displays object list.....	20

1 Information on the product

1.1 Product catalogue

Product name:	KNX-Gateway
Use:	Gateway
Design:	Installation
Art.-no.	4511630

1.2 Function

The KNX gateway forms the interface between a KNX installation and a door drive with HCP bus connection.

It allows the drive to be controlled by the KNX and the status information of the drive to be transferred to the KNX. Depending on the selected drive type, there are communication objects available adapted to this.

Operating errors due to an incorrectly set drive type are excluded.

The connection is made via a plug connector protected against reverse polarity.

The power supply of the KNX gateway is provided by the door drive.

1.3 Device components

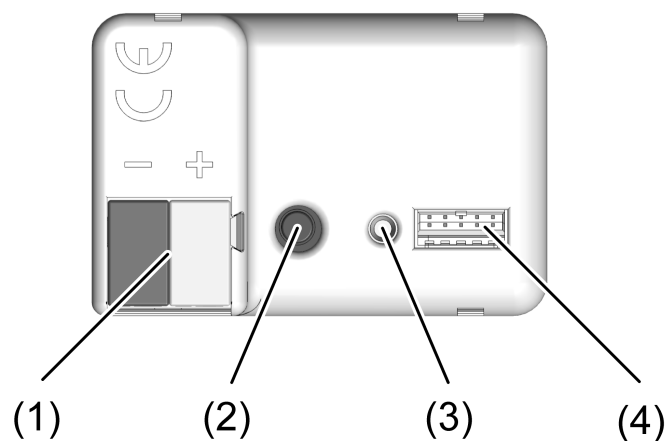

Image 1: Device components

- (1) KNX connection
- (2) Programming button
- (3) Programming LED
- (4) Connection socket for the enclosed connecting cable

1.4 Technical data

Bus

Rated voltage	DC 24 V SELV (+10%, -25%)
Current consumption	typ. < 5 mA
Ambient conditions	
Ambient temperature	-20 ... +60 °C
Storage/transport temperature	-20 ... +70 °C
Rel. humidity (storage/transport)	max. 93% (without condensation)
Dimensions	
Dimensions L×W×H	44x29x16 mm
Connecting cable	approx. 70 mm
KNX	
KNX medium	TP256
Commissioning mode	S-mode
Rated voltage KNX	DC 21 ... 32 V SELV
Current consumption KNX	2.5 ... 3 mA
Connection mode KNX	device connection terminal

2 Safety instructions



Electrical devices may only be mounted and connected by electrically skilled persons.

Serious injuries, fire or property damage possible. Please read and follow manual fully.

Danger of electric shock. Always disconnect before carrying out work on the device or load.

The device may not be opened or operated outside the technical specifications.

These instructions are an integral part of the product, and must remain with the end customer.

3 Fitting and electrical connection



DANGER!

Electrical shock on contact with live parts in the installation environment.

Electrical shocks can be fatal.

Before working on the device, disconnect the power supply and cover up live parts in the working environment.

Preparing the operator for installation

- Disconnect the power supply of the operator.
- Open the connection compartment of the operator.

Connect device to KNX as shown in the connection example (see figure 2)

- Connect bus line with enclosed connecting terminal to connection KNX (1).

Connect device to door operator as shown in the connection example (see figure 2)

- Insert the MOLEX plug (5) of the enclosed connecting cable into the connection socket (4) on the device with slight pressure and lock into place.
- Connect the RJ12 plug (6) of the enclosed connecting cable to the corresponding socket on the door operator (see operator instructions).

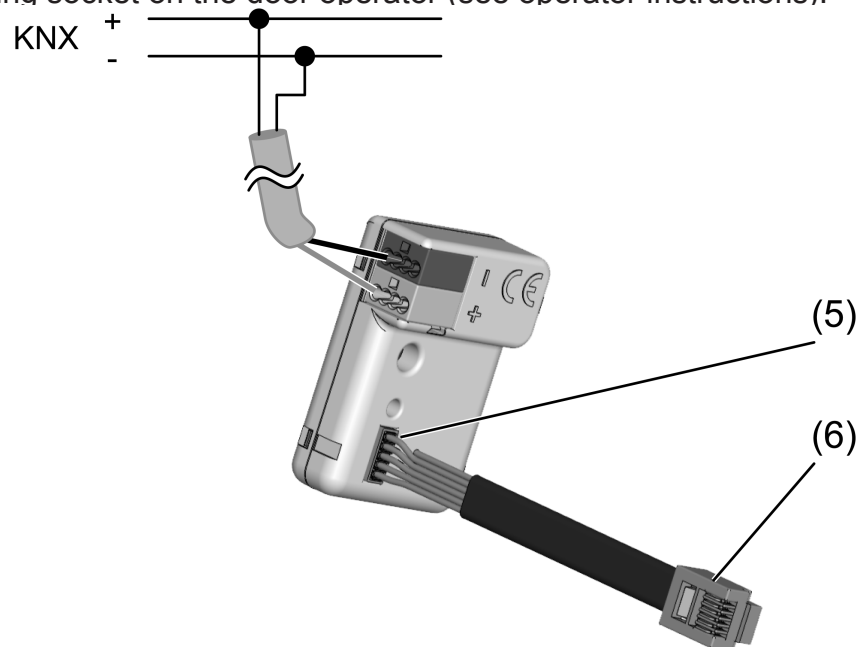

Image 2: Connection example

Fitting the device in the door operator

- Insert the device so it fits into the connection compartment of the door operator.

- Reconnect the power supply of the operator.
- Start the bus scan on the operator (see operator instructions).

4 Commissioning

Programming the physical address and application program

- i** Programming is not possible without connection to the door operator and a successfully completed bus scan.

Precondition: The device is connected to the KNX and the door operator and ready for operation.

- Switch on the bus voltage.
- Press the programming button (2).
The programming LED (3) lights up.
- Programming the physical address.
The programming LED goes out.
- Write the physical address on the device label.
- Programming the application program.
The device is in operation.

5 Application programs

ETS search paths:	Gateway / KNX-Gateway
-------------------	-----------------------

Name	KNX interface A04011
Version:	1.1
from mask version	for ETS5 from Version 5.7.3 onwards and ETS6 SystemB (07B0)
Summarized de- scription	Communication between KNX and door drives with HCP bus connection.

6 Scope of functions

General

- Communication between KNX and drives with HCP bus connection
- Control of a drive according to the KNX standard or with pulse sequence.
- Control and status objects adapted to the functional scope of the drive
- Actively transmitting feedback or status messages can be delayed globally after bus voltage return or after ETS programming.

7 Notes on software

Unloading the application program

The application program can be unloaded with the ETS. In this case the device is without function.

ETS project design and commissioning

For project design and commissioning of the device, ETS5 from Version 5.7.3 onwards or ETS6 is required. Project designing and commissioning of the device using ETS2, ETS3 or ET4 is not possible.

8 Name of the drive

You can optionally assign a name for the drive. The name is intended to illustrate the use of the drive (e.g. "garage left", "delivery entrance"). The names are only used in the ETS in the text of the parameter pages and communication objects.

8.1 Name of the drive parameter

Configuration -> Name of the drive

Name of the drive	Free text
<p>The text entered in this parameter is applied to the name of the communication objects and is used for labelling the drive in the ETS parameter window (e.g. "garage left", "delivery entrance").</p> <p>The text is not programmed in the device.</p>	

9 Drive type

The gateway enables the connection of a door drive with HCP-2 bus to KNX. As the door drives have a different scope of functions, the first step is to select the drive type. Depending on the drive type selected, additional parameters and communication objects are then displayed.

The supported drives are divided into two groups. The garage door drives include Liftronic, SupraMatic, RollMatic and ProMatic with different variants. The industrial drives include WA500, WA500FU, ITO500FU, WA500FUSTA, DD drive and DDS6 drive.

In contrast to the industrial drives, the garage door drives have the following characteristics:

- Switching the lighting integrated in the drive
- Approach a manual ventilation position
- Evaluating the climate sensor for automatic activation of a ventilation position
- Disabling the operation with the exception of the local operation in the garage.

In contrast to the garage door drives, the industrial drives have the following characteristics:

- Automatic closing after an adjustable hold-open time.
- Traffic light control for entrance and exit

9.1 Drive type parameter

Configuration -> Basic settings

Drive type	WA500 WA500FU ITO500FU WA500FUSTA DD drive DDS6 drive DC drive (Liftronic) DC drive (SupraMatic E) DC drive (SupraMatic P) not assigned Interior roller (RollMatic) Exterior roller (RollMatic) DC drive (ProMatic)
<p>The KNX gateway can control various drives. This parameter defines which drive type is connected.</p> <p>The ETS adapts further parameters and communication objects dynamically depending on this parameter. For this reason, the "Drive type" parameter should be set before all other parameters.</p>	

10 Drive movement

The KNX gateway can use various communication objects to control the drive.

With the "Open / Close" setting, the KNX gateway provides two communication objects in accordance with the KNX standard for controlling Venetian blind or shutter drives. With these communication objects, you can select a direction of travel and stopping.

- i** For the "Open / Close" setting, the operating mode "Immediate reversal of direction with direction command" must be set in the advanced menu of the drive.

With the "Open / Stop / Close" setting, the KNX gateway provides a 1-bit communication object. With each receipt, the drive automatically changes the direction of travel.

10.1 Drive movement parameter

Configuration -> Basic settings

Drive movement	Open / Close Open / Stop / Close
<p>With the "Open / Close" setting, the ETS provides two communication objects in accordance with the KNX standard for controlling Venetian blind or shutter drives. With these communication objects, you can select a direction of travel and stopping.</p> <ul style="list-style-type: none"> i For the "Open / Close" setting, the operating mode "Immediate reversal of direction with direction command" must be set in the advanced menu of the drive. <p>With the "Open / Stop / Close" setting, the ETS provides a communication object. With each receipt, the drive automatically changes the direction of travel.</p>	

10.2 Drive movement object list

Object no.	Function	Name	Type	DPT	Flag
1	Move drive	Drive ... - Input	1-bit	1,008	C, -, W, -, -
<p>1-bit object to move the drive. Receipt of a telegram with the value 0 results in opening. Receipt of a telegram with the value 1 results in the door closing. Receipt of a command to change the direction during door movement results in the drive stopping for the time parameterised in the drive and then starting again in the desired direction.</p> <p>The object is only available if the "Drive movement" parameter is set to "Open / Close".</p>					

Object no.	Function	Name	Type	DPT	Flag
2	Stop drive	Drive (...) - Input	1-bit	1,017	C, -, W, -, -
<p>1-bit object for stopping a drive movement. Receipt of a telegram stops the drive.</p> <p>The object is only available if the "Drive movement" parameter is set to "Open / Close".</p>					
Object no.	Function	Name	Type	DPT	Flag
3	Approach manual ventilation position 1	Drive (...) - Input	1-bit	1,001	C, -, W, -, -
<p>1-bit object to activate the ventilation position programmed on the drive. After receipt of a telegram with the value "1", the drive moves to the programmed ventilation position. After receipt of a telegram with the value "0", the drive closes the door.</p> <p>The object is only available for garage door drives.</p>					
Object no.	Function	Name	Type	DPT	Flag
4	Approach automatic ventilation position 1	Drive (...) - Input	1-bit	1,001	C, -, W, -, -
<p>1-bit object to activate the ventilation position programmed on the drive. After receipt of a telegram with the value "1", the drive moves to the programmed ventilation position depending on the state of the climate sensor connected. After receipt of a telegram with the value "0", the drive closes the door.</p> <p>The object is only available for garage door drives.</p>					
Object no.	Function	Name	Type	DPT	Flag
5	Move to sub-position 1/2-Open	Drive (...) - Input	1-bit	1,001	C, -, W, -, -
<p>1-bit object to activate the customer-specific door position programmed on the drive. After receipt of a telegram with the value "1", the drive moves to the programmed door position. After receipt of a telegram with the value "0", the drive closes the door.</p>					
Object no.	Function	Name	Type	DPT	Flag
6	Open / Stop / Close pulse	Drive (...) - Input	1-bit	1,017	C, -, W, -, -
<p>1-bit object to control the drive with a pulse sequence. With each telegram received, the next state is adopted: Open - Stop - Close - Stop.</p> <p>The object is only available if the "Drive movement" parameter is set to "Open / Stop / Close".</p>					

11 Drive lighting

With garage door drives, the integrated lighting can be controlled via KNX. The "Drive lighting" parameter can be used to select one of two functions. In the "Switch on / off" default setting, the object value determines the state of lighting. In the "Toggle" setting, the drive alternately switches the lighting on and off for each new telegram with the value "1". Telegrams with the value "0" are ignored.

11.1 Drive lighting parameter

Configuration -> Basic settings

Drive lighting	Switch on/off Toggle
<p>This parameter determines the drive lighting function.</p> <p>In the default setting, the communication object "Switch on / off drive lighting" is displayed. If the communication object receives the value "1", the lighting is switched on. If the communication object receives the value "0", the lighting is switched off. If the same value is received multiple times, the lighting state does not change.</p> <p>With the "Toggle" setting, the communication object "Toggle drive lighting" is displayed. If the communication object receives the value "1", the lighting is alternately switched on and off. If the communication object receives the value "0", the lighting state does not change.</p> <p>The parameter is only available for drives with integrated lighting.</p>	

11.2 Drive lighting object list

Object no.	Function	Name	Type	DPT	Flag
7	Switch on / off drive lighting	Drive (...) - Input	1-bit	1,001	C, -, W, -, -
<p>1-bit object for switching the drive lighting on or off ("1" = Switch on / "0" = Switch off).</p> <p>This object is only available if the drive lighting is configured to "Switch on / off".</p>					
Object no.	Function	Name	Type	DPT	Flag
7	Toggle drive lighting	Drive (...) - Input	1-bit	1,001	C, -, W, -, -
<p>1-bit object for toggling the drive lighting ("1" = Alternately switching on and off / "0" = No response).</p> <p>This object is only available if the drive lighting is configured to "Toggle".</p>					
Object no.	Function	Name	Type	DPT	Flag
17	Drive lighting status	Drive (...) - Output	1-bit	1,001	C, R, -, T, -
<p>1-bit object for feedback signalling of the switching state ("1" = On / "0" = Off) to the bus.</p>					

12 Behaviour in case of restart

During a restart, the KNX gateway determines all current status information of the drive. As soon as the KNX gateway detects status changes during operation, it transmits these changes via the corresponding communication objects.

In particular after a restart of the entire KNX installation as a result of the bus voltage being switched back on, the status messages can cause a high bus load. In addition, visualisation devices may require some time after a restart before they can receive and display new status messages. For these reasons, the behaviour of the KNX gateway can be parameterised.

The "Behaviour after bus voltage return" parameter can be used to activate or deactivate the status messages in this case.

In the event of a KNX gateway restart which is not caused by the return of KNX bus voltage, the "Behaviour after reset" parameter determines whether the KNX gateway transmits the status messages.

In both cases, the KNX gateway also takes into account the time set with the "Delay after bus voltage return" parameter.

12.1 Behaviour after bus voltage return parameter

Configuration -> Basic settings

Behaviour after bus voltage return	no reaction Transmit current state
<p>The actuator enables status feedback messages to be transmitted after bus voltage return.</p> <p>No response: The device does not transmit current status feedback. The status feedback is only transmitted after the next change of the device status.</p> <p>Transmit the current status: The device transmits the current status feedback after bus voltage return and the additionally set delay time.</p>	
Behaviour after a device reset	no reaction Transmit current state
<p>The actuator enables status feedback to be transmitted after a device reset.</p> <p>No response: The device does not transmit current status feedback. The status feedback is only transmitted after the next change of the device status.</p> <p>Transmit the current status: The device transmits the current status feedback after a device reset.</p>	

Delay after bus voltage return or a device reset	0 ... 59 min 0 ... 17 ... 59 s
To reduce telegram traffic on the bus line after bus voltage activation (bus reset), after connection of the device to the bus line or after programming with the ETS, it is possible to delay all active feedback telegrams of the actuator. The parameter specifies in this case a delay valid for all devices. Only after the time configured here has elapsed are feedback telegrams for initialisation transmitted to the bus.	

13 Status displays

During a restart, the KNX gateway determines all current status information of the drive. As soon as the KNX gateway detects status changes during operation, it transmits these changes via the corresponding communication objects.

The status messages possible depend on the drive type. The status communication objects for drive lighting, ventilation position and drive disabling are only available for garage door drives.

The status communication objects for traffic light control are only available for industrial drives.

The polarity can be set for the two communication objects "Door open status" and "Door closed status". In the default setting, the communication object "Door open status" has the value "1" if the door is fully open, and the communication object "Door closed status" has the value "1" if the door is fully closed. Otherwise the communication objects have the value "0". If necessary, the value can be inverted independently for both objects.

13.1 Status displays parameter

Configuration -> Status displays

Object polarity "Door open status"	1 = Open 0 = Open
This parameter defines the polarity of the "Door open status" object. The set value is transmitted immediately after the door is fully open. The inverted value is transmitted immediately upon closing.	

Object polarity "Door closed status"	1 = Closed 0 = Closed
This parameter defines the polarity of the "Door closed status" object. The set value is transmitted immediately after the door is fully closed. The inverted value is transmitted immediately upon opening.	

13.2 Status displays object list

Object no.	Function	Name	Type	DPT	Flag
11	Door open status	Drive (...) - Output	1-bit	1,002	C, R, -,T, -
1-bit object for feedback signalling of the opening status of the door. The value depends on the parameter of the "Door open status" object polarity.					

Object no.	Function	Name	Type	DPT	Flag
12	Door closed status	Drive (...) - Output	1-bit	1,002	C, R, -,T, -
1-bit object for feedback signalling of the opening status of the door. The value depends on the parameter of the "Door closed status" object polarity.					

Object no.	Function	Name	Type	DPT	Flag
13	Door status in manual ventilation position 1	Drive (...) - Output	1-bit	1,002	C, R, -,T, -
<p>1-bit object for feedback signalling of the opening status of the door.</p> <p>The object has the value "1" when the door has approached the ventilation position. Otherwise it has the value "0".</p>					
Object no.	Function	Name	Type	DPT	Flag
14	Door position status	Drive (...) - Output	1 bytes	5,001	C, R, -,T, -
<p>1-bit object for feedback signalling of the opening status of the door.</p> <p>The object is transmitted when the door position changes. When the door is fully open, the value is "0%". When the door is fully closed, the value is "100%".</p>					
Object no.	Function	Name	Type	DPT	Flag
15	Drive movement open status	Drive (...) - Output	1-bit	1,002	C, R, -,T, -
<p>1-bit object for feedback signalling of the door drive movement.</p> <p>The object has the value "1" when the door is opened. Otherwise it has the value "0".</p>					
Object no.	Function	Name	Type	DPT	Flag
16	Drive movement close status	Drive (...) - Output	1-bit	1,002	C, R, -,T, -
<p>1-bit object for feedback signalling of the door drive movement.</p> <p>The object has the value "1" when the door is closed. Otherwise it has the value "0".</p>					
Object no.	Function	Name	Type	DPT	Flag
18	Red traffic light entrance status	Drive (...) - Output	1-bit	1,002	C, R, -,T, -
19	Yellow traffic light entrance status	Drive (...) - Output	1-bit	1,002	C, R, -,T, -
20	Green traffic light entrance status	Drive (...) - Output	1-bit	1,002	C, R, -,T, -
21	Red traffic light exit status	Drive (...) - Output	1-bit	1,002	C, R, -,T, -
22	Yellow traffic light exit status	Drive (...) - Output	1-bit	1,002	C, R, -,T, -
23	Green traffic light exit status	Drive (...) - Output	1-bit	1,002	C, R, -,T, -
<p>1-bit objects for feedback signalling of the door's traffic lights.</p> <p>The objects have the value "1" when the corresponding signals are illuminated. Otherwise they have the value "0".</p> <p>The objects are only available for drives with traffic lights.</p>					

Object no.	Function	Name	Type	DPT	Flag
24	Pre-warning time active status	Drive (...) - Output	1-bit	1,002	C, R, -,T, -
<p>1-bit object for feedback signalling of the door's pre-warning time.</p> <p>The object has the value "1" if the pre-warning time is active before closing the door. Otherwise it has the value "0".</p>					
Object no.	Function	Name	Type	DPT	Flag
25	Hold-open time active status	Drive (...) - Output	1-bit	1,002	C, R, -,T, -
<p>1-bit object for feedback signalling of the door's hold-open time.</p> <p>The object has the value "1" if the hold-open time is active before automatic closing. Otherwise it has the value "0".</p>					
Object no.	Function	Name	Type	DPT	Flag
26	Inspection required status	Drive (...) - Output	1-bit	1,002	C, R, -,T, -
<p>1-bit object for feedback signalling of the door's required inspection.</p> <p>The object has the value "1" when an inspection is required. Otherwise it has the value "0".</p>					
Object no.	Function	Name	Type	DPT	Flag
27	Error status (high priority)	Drive (...) - Output	1-bit	1,002	C, R, -,T, -
<p>1-bit object for feedback signalling of a high priority error.</p> <p>The object has the value "1" when a high priority error is present. Otherwise it has the value "0".</p>					
Object no.	Function	Name	Type	DPT	Flag
28	Error status (low priority)	Drive (...) - Output	1-bit	1,002	C, R, -,T, -
<p>1-bit object for feedback signalling of a low priority error.</p> <p>The object has the value "1" when a low priority error is present. Otherwise it has the value "0".</p>					
Object no.	Function	Name	Type	DPT	Flag
29	Drive disabled status	Drive (...) - Output	1-bit	1,002	C, R, -,T, -
<p>1-bit object for feedback signalling of a disabling of the drive.</p> <p>The object has the value "1" when the drive is disabled. In this case only on-site operation in the garage is possible. Otherwise it has the value "0".</p>					

Object no.	Function	Name	Type	DPT	Flag
30	Partial opening active status	Drive (...) - Output	1-bit	1,002	C, R, -,T, -

1-bit object for feedback signalling of the door's partial opening.

The object has the value "1" when the door has reached the programmed partial opening position. Otherwise it has the value "0".

Object no.	Function	Name	Type	DPT	Flag
31	Power-On counter	Drive (...) - Output	4 bytes	12,001	C, R, -,T, -

4-byte object for feedback signalling of the number of new currents applied to the drive.

Value range: 0...4294967295

Object no.	Function	Name	Type	DPT	Flag
32	Factory reset counter	Drive (...) - Output	4 bytes	12,001	C, R, -,T, -

4-byte object for feedback signalling of the number of resets of the drive.

Value range: 0...4294967295

Object no.	Function	Name	Type	DPT	Flag
34	Incomplete door cycles counter	Drive (...) - Output	4 bytes	12,001	C, R, -,T, -

4-byte object for feedback signalling of the number of incomplete opening / closing processes.

Value range: 0...4294967295

Object no.	Function	Name	Type	DPT	Flag
35	Complete door cycles counter	Drive (...) - Output	4 bytes	12,001	C, R, -,T, -

4-byte object for feedback signalling of the number of complete opening / closing processes.

Value range: 0...4294967295

Object no.	Function	Name	Type	DPT	Flag
36	Incomplete door cycles counter after last maintenance	Drive (...) - Output	4 bytes	12,001	C, R, -,T, -

4-byte object for feedback signalling of the number of incomplete opening / closing processes since the last maintenance.

Value range: 0...4294967295

Object no.	Function	Name	Type	DPT	Flag
37	Movement commands counter	Drive (...) - Output	4 bytes	12,001	C, R, -,T, -
4-byte object for feedback signalling of the number of movement commands of the drive. Value range: 0...4294967295					
Object no.	Function	Name	Type	DPT	Flag
38	Total drive runtime counter (seconds)	Drive (...) - Output	4 bytes	13,100	C, R, -,T, -
4-byte object for feedback signalling of the drive's runtime. Value range: 0...2147483647 seconds					
Object no.	Function	Name	Type	DPT	Flag
39	Total drive runtime counter (hours)	Drive (...) - Output	2 bytes	7,007	C, R, -,T, -
2-byte object for feedback signalling of the drive's runtime. Value range: 0...65,535 hours					
Object no.	Function	Name	Type	DPT	Flag
40	Drive runtime since last maintenance counter (seconds)	Drive (...) - Output	4 bytes	13,100	C, R, -,T, -
4-byte object for feedback signalling of the door's runtime since the last maintenance. Value range: 0...2147483647 seconds					
Object no.	Function	Name	Type	DPT	Flag
41	Drive runtime since last maintenance counter (hours)	Drive (...) - Output	2 bytes	7,007	C, R, -,T, -
2-byte object for feedback signalling of the door's runtime since the last maintenance. Value range: 0...65,535 hours					
Object no.	Function	Name	Type	DPT	Flag
42	Operating hours counter (total)	Drive (...) - Output	4 bytes	13,100	C, R, -,T, -
4-byte object for feedback signalling of the drive's operating time. Value range: 0...2147483647 seconds					
Object no.	Function	Name	Type	DPT	Flag
43	Temperature	Drive (...) - Output	2 bytes	9,001	C, R, -,T, -
2-byte object for feedback signalling of the current temperature value of the climate sensor connected to the drive.					

Object no.	Function	Name	Type	DPT	Flag
44	Humidity	Drive (...) - Output	2 bytes	9,007	C, R, -,T, -
2-byte object for feedback signalling of the relative humidity of the climate sensor connected to the drive.					

Object no.	Function	Name	Type	DPT	Flag
45	Dew point	Drive (...) - Output	2 bytes	9,007	C, R, -,T, -
2-byte object for feedback signalling of the current dew point temperature value of the climate sensor connected to the drive.					

Object no.	Function	Name	Type	DPT	Flag
46	Lock status	Drive (...) - Output	1-bit	1,002	C, R, -,T, -
1-bit object for feedback signalling of the lock status of the door. The object has the value "1" when the door is locked. Otherwise it has the value "0".					

Object no.	Function	Name	Type	DPT	Flag
47	Configuration error	Drive (...) - Output	1-bit	1,002	C, R, -,T, -
1-bit object for feedback signalling of a configuration error. The object has the value "1" when the parameterised drive type does not correspond to the connected drive type. Otherwise it has the value "0".					

Object no.	Function	Name	Type	DPT	Flag
48	Door position invalid	Drive (...) - Output	1-bit	1,002	C, R, -,T, -
1-bit object for feedback signalling of an invalid position of the door. The object has the value "1" when the position feedback is invalid. Otherwise it has the value "0".					

HÖRMANN KG Verkaufsgesellschaft

Upheider Weg 94-98

33803 Steinhagen