

Valve drive (motor-operated) with controller

Art. No. : 2177SVR

Operating instructions**1 Safety instructions**

Electrical devices may only be mounted and connected by electrically skilled persons.

Serious injuries, fire or property damage possible. Please read and follow manual fully.

These instructions are an integral part of the product, and must remain with the end customer.

2 Device components

Figure 1

- (1) Position display
- (2) Knurled nut M30×1.5
- (3) Status LED
- (4) Cover
- (5) Screw
- (6) Connecting cable

3 Function**System information**

This device is a product of the KNX system and complies with the KNX directives. Detailed technical knowledge obtained in KNX training courses is a prerequisite to proper understanding.

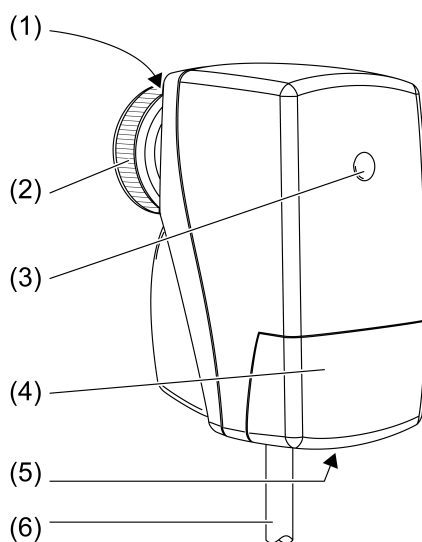
The function of this device depends upon the software. Detailed information on loadable software and attainable functionality as well as the software itself can be obtained from the manufacturer's product database.

Planning, installation and commissioning of the device are carried out with the aid of KNX-certified software. Full functionality with KNX commissioning software version ETS4 and higher.

An updated version of the product database, technical descriptions and conversion programs and other auxiliary programs are available on our Internet website.

Intended use

- Motorised valve drive for heating or cooling valves
- Screw onto valve head

The valve drive is matched to standard valve base types using an M30×1.5 connection. In the basic setting, the valve drive fits the valve bases of make Heimeier. Adapters must be used for valve bases of other manufacturers. No function guarantee can be accepted for this.

Product characteristics

- Integrated temperature sensor
- Room temperature control
- Mechanical display of the valve stroke
- Automatic detection of the valve stroke
- An input, which can be used as a binary input or for an external temperature sensor
- Use in heating circuit distributor possible
- Integrated bus coupling unit
- Valve protection function

4 Information for electrically skilled persons**4.1 Mounting and electrical connection****Mounting the valve drive**

- Attach the valve drive to the valve base with slight pressure.
- Screw on the knurled nut (2) and hand-tighten it.

Connecting the valve drive

Figure 2: Valve drive with opened cover

- (7) Strain relief
- (8) Blanking plug
- (9) Programming button
- (10) Device connection terminal for potential-free contact or external temperature sensor

- Connect the connection cable (6) to KNX.
- Secure the connection cable (6) at the junction point using strain relief.

i Observe the cable routing. The connection cable may not come into prolonged contact with elements conducting heat, e.g. heating pipe or radiator.

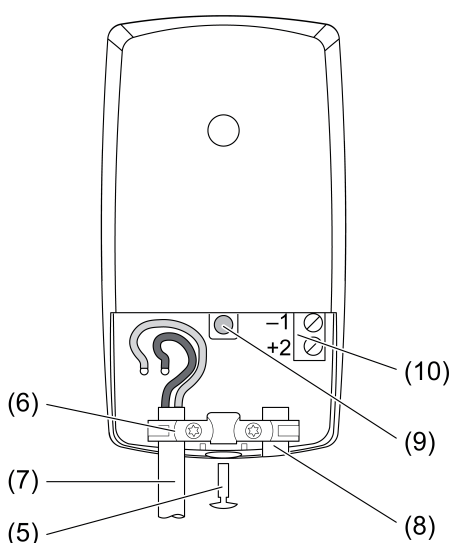
Connecting an external contact or external temperature sensor

Use a cable with a diameter of 5 mm to connect a potential-free contact or a temperature sensor.

- Slacken the screw (5) with Torx-7 and open the cover (4).
- Slacken the strain relief (7) on both sides with Torx-7.
- Remove the blanking plug (8).
- Insert the connection cable for the potential-free contact or temperature sensor through the open cable entry into the terminal compartment.
- Connect the connection cable to the terminal (10).
- Fix the connecting cable with the strain relief (7).
- Close the cover (4).

4.2 Commissioning

Loading the physical address and application software

- Switch on the bus voltage.
- Slacken the screw (5) with Torx-7 and open the cover (4).
- Press the programming button (9).
The status LED (3) lights up.
- Assign physical address.
The status LED goes out.
- Load the application software.
- Close the cover (4).

i After the application software is loaded and after each switch-on of the bus voltage, the valve drive will perform an initialisation operation to adjust itself to the valve stroke.

5 Appendix

5.1 Technical data

KNX	
KNX medium	TP
Commissioning mode	S-mode
Rated voltage KNX	DC 21 ... 32 V SELV
Current consumption KNX	max. 20 mA
Protection class	III
Mechanism	
Valve connection	M30×1.5
Stroke	1.0 ... 4.2 mm
Positioning force	80 ... 120 N
Noise emission	max. 28 dB(A)
Dimensions L×W×H	76×47×85 mm
Connecting cable	
Cable type	J-YY 1×2×0.6 mm
Cable length	1 m
Total length per line	max. 30 m
Number of drives per line	max. 30
Connection cable, binary input/remote sensor	
Poll voltage, extension inputs	approx. 3.3 V
Cable length	max. 10 m
single stranded	0.08 ... 1.5 mm ²
Finely stranded without conductor sleeve	0.08 mm ² ... 1.0 mm ²
Finely stranded with conductor sleeve	0.14 mm ² ... 0.5 mm ²
Ambient conditions	
Degree of protection	IP 40
Ambient temperature	0 ... +50 °C

Valve drive (motor-operated) with controller

Storage/transport temperature
Relative humidity

-20 ... +70 °C
5 ... 95 % (No moisture condensation)

5.2 Accessories

External sensor

Art. No. FF7.8

5.3 Warranty

The warranty follows about the specialty store in between the legal framework as provided for by law.

ALBRECHT JUNG GMBH & CO. KG

Volmestraße 1
58579 Schalksmühle
GERMANY

Telefon: +49 2355 806-0
Telefax: +49 2355 806-204
kundencenter@jung.de
www.jung.de